

NOTES UNLESS OTHERWISE SPECIFIED

1. PARENT MATERIAL: 304 STAINLESS STEEL, 14 GAUGE (0.075" THICK)
2. PART IS SEAMLESS, FORMED FROM SHEET METAL WITHOUT WELDS.
3. FINISH: NO METAL FINISHING REQUIRED. THE FINAL FINISH SHALL BE THE RESULT OF THE PROCESSES USED TO FABRICATE THE SHAPE, RESULTING IN AN ESTIMATED SURFACE ROUGHNESS OF 80 Ra.
4. PART IS NOT DESIGNED FOR PRESSURE OR VACUUM APPLICATIONS.

REVISIONS			
REV.	DESCRIPTION	DATE	APPROVED
00	PRELIMINARY COPY - NOT RELEASED FOR MANUFACTURING	DEC2001	J. KNAPP
A	UPDATED TO 14 GA (.075")	18OCT2022	A. FULKERT
B	ADDED NOTE REFERENCING PRESSURIZED LIDS.	3NOV2023	C. FANKHAUSER

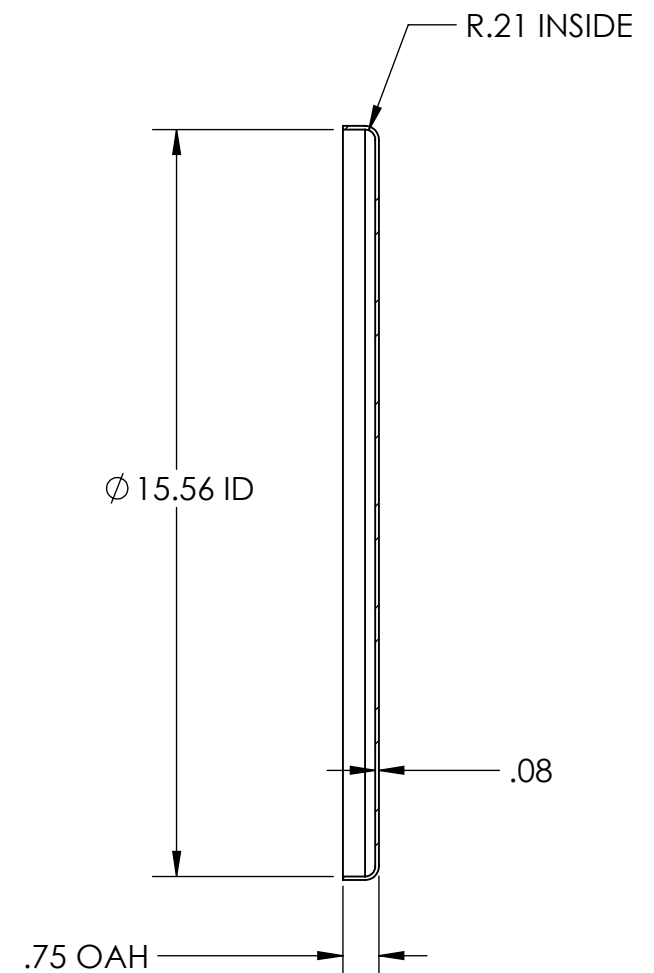
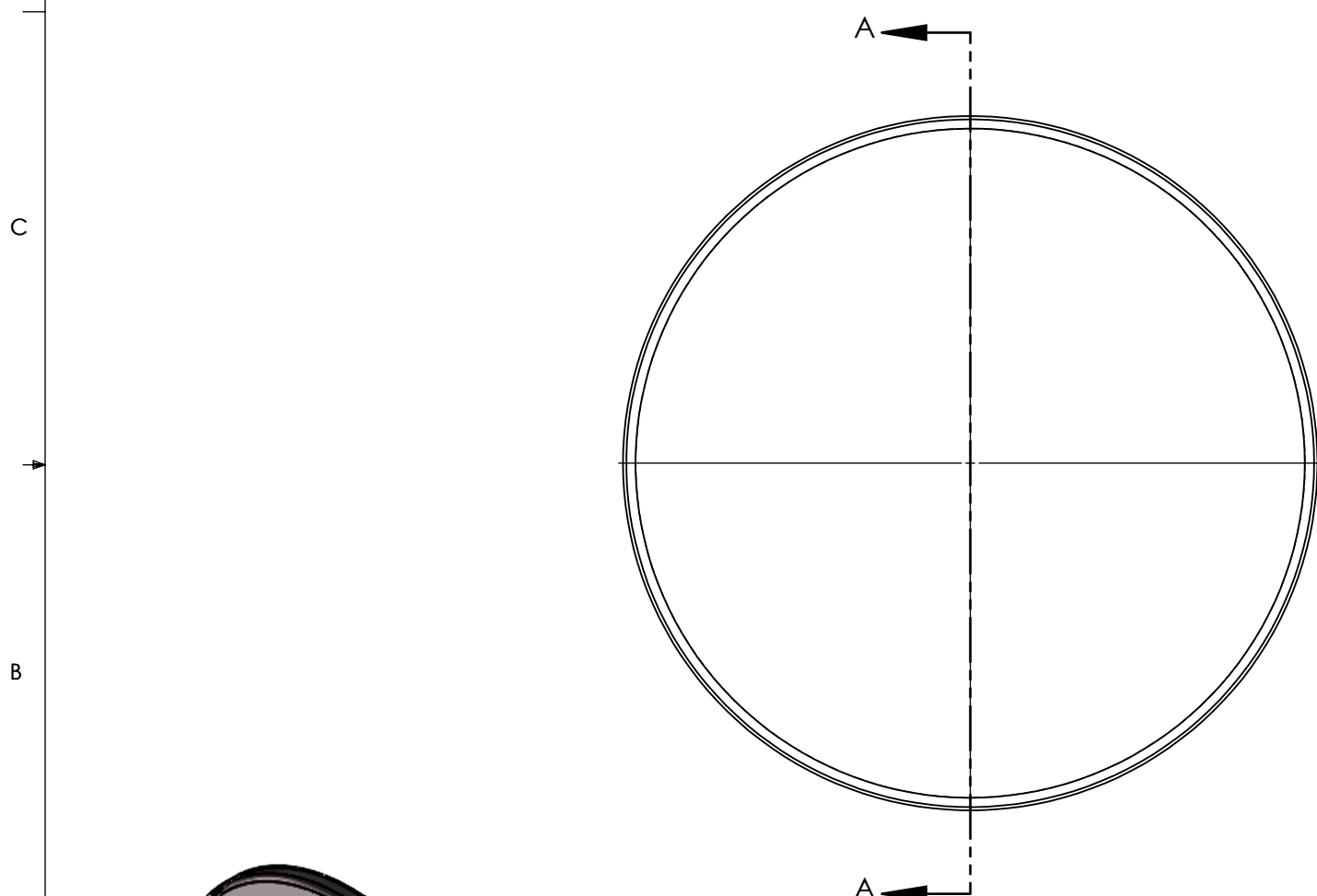

SECTION A-A

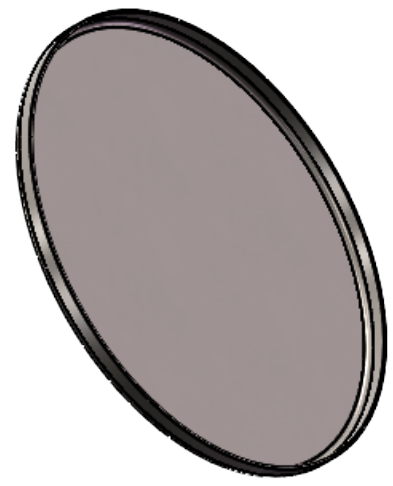

UNLESS OTHERWISE SPECIFIED: 1. DO NOT SCALE DRAWING 2. DIMENSIONS ARE IN INCHES 3. TOLERANCE: FRACTIONAL ± .25 X.X ±.1 X.XX ±.03 X.XXX ±.010 ANGULAR: ±2 DEG. 4. INTERPRET DRAWING PER ASME-Y14.5M-1994 STANDARDS 5. THIRD ANGLE PROJECTION 6. REMOVE BURRS & BREAK ALL SHARP EDGES WITH R0.03 ±.02	DRAWN	J. ASHBY	18OCT2022	TOLEDO METAL SPINNING EST. 1929 TITLE: TMS 304SS LID
	CHECKED			
	ENG APPR.			
	MFG APPR.			
	Q.A.			
	PROPRIETARY AND CONFIDENTIAL			
THE INFORMATION CONTAINED WITHIN THIS DRAWING IS THE SOLE PROPERTY OF TOLEDO METAL SPINNING COMPANY. ANY REPRODUCTION IN PART OR AS A WHOLE WITHOUT WRITTEN PERMISSION OF TOLEDO METAL SPINNING COMPANY IS PROHIBITED.				SIZE DRAWING NUMBER B TMSL1414
SCALE: 1:4			WEIGHT: 4.81	REV SHEET 1 OF 1 B