

**NOTES UNLESS OTHERWISE SPECIFIED**

1. PARENT MATERIAL: 304 STAINLESS STEEL, 14 GAUGE (0.075" THICK)
2. PART IS SEAMLESS, FORMED FROM SHEET METAL WITHOUT WELDS.
3. FINISH: NO METAL FINISHING REQUIRED. THE FINAL FINISH SHALL BE THE RESULT OF THE PROCESSES USED TO FABRICATE THE SHAPE, RESULTING IN AN ESTIMATED SURFACE ROUGHNESS OF 80 Ra.

REVISIONS			
REV.	DESCRIPTION	DATE	APPROVED
00	PRELIMINARY COPY - NOT RELEASED FOR MANUFACTURING	DEC2001	J. KNAPP
A	UPDATED TO 14 GA.	18OCT2022	A. FULKERT

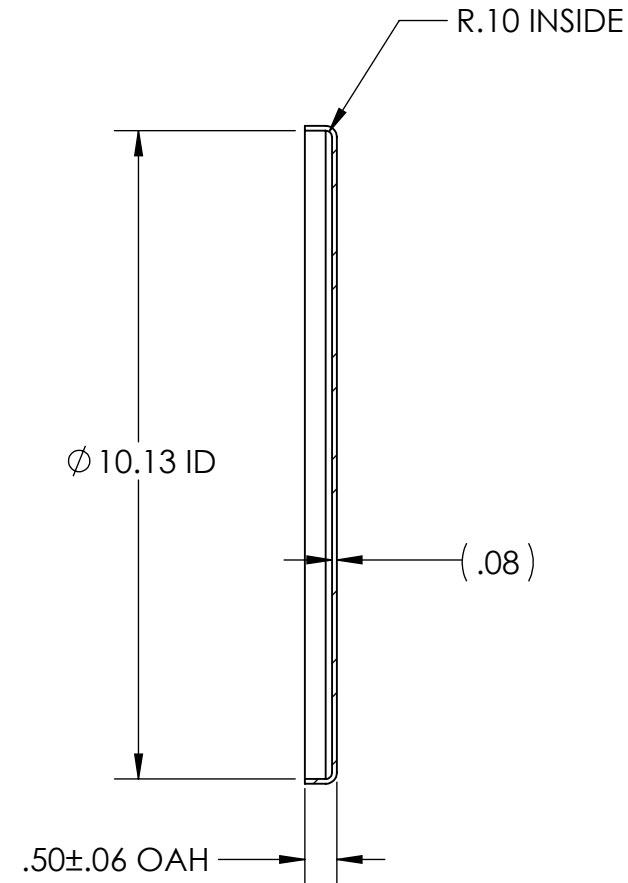
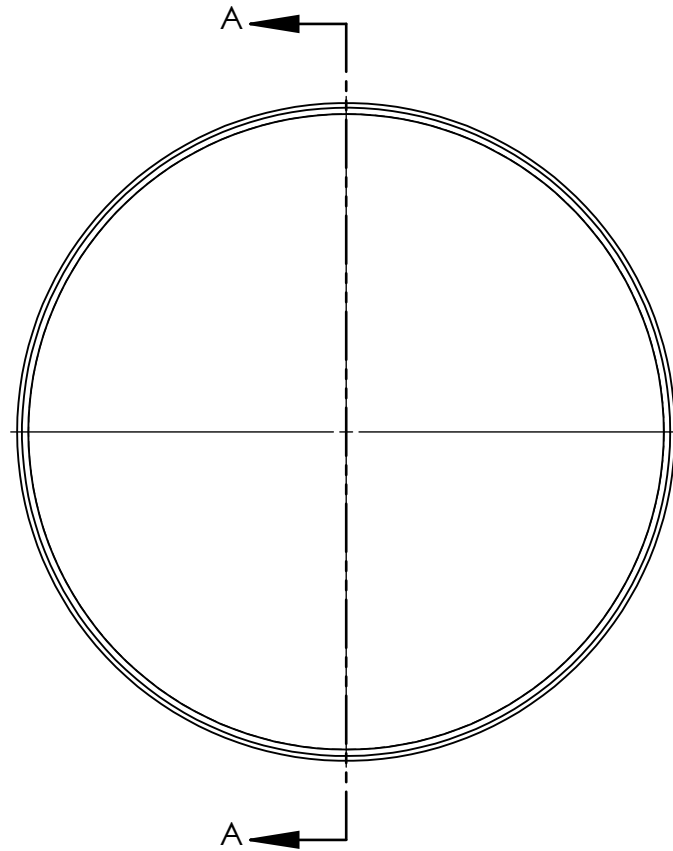

SECTION A-A  
SCALE 1 : 3

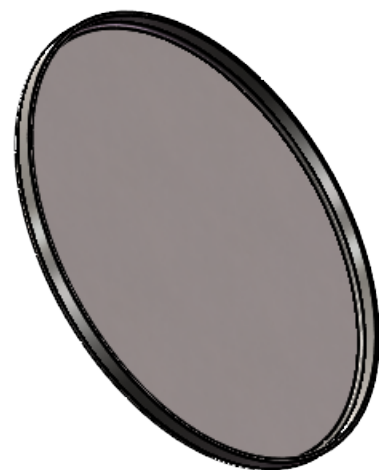

UNLESS OTHERWISE SPECIFIED: 1. DO NOT SCALE DRAWING 2. DIMENSIONS ARE IN INCHES 3. TOLERANCE: FRACTIONAL $\pm .25$ X.X $\pm .1$ X.XX $\pm .03$ X.XXX $\pm .010$ ANGULAR: $\pm 2 \text{ DEG.}$ 4. INTERPRET DRAWING PER ASME-Y14.5M-1994 STANDARDS 5. THIRD ANGLE PROJECTION 6. REMOVE BURRS & BREAK ALL SHARP EDGES WITH $R0.03 \pm .02$	DRAWN	J. ASHBY	18OCT2022	<b>TOLEDO METAL SPINNING EST. 1929</b>  TITLE: TMS 304SS LID
	CHECKED			
	ENG APPR.			
	MFG APPR.			
	Q.A.			
	<b>PROPRIETARY AND CONFIDENTIAL</b>			
THE INFORMATION CONTAINED WITHIN THIS DRAWING IS THE SOLE PROPERTY OF TOLEDO METAL SPINNING COMPANY. ANY REPRODUCTION IN PART OR AS A WHOLE WITHOUT WRITTEN PERMISSION OF TOLEDO METAL SPINNING COMPANY IS PROHIBITED.				SIZE DRAWING NUMBER <b>B TMSL914</b>
SCALE: 1:4			WEIGHT: 2.05	REV <b>A</b>
SHEET 1 OF 1				